

HSEW

'JOHN CRANE TYPE SEW - SAFEMATIC' SPECIFICATION SHEET

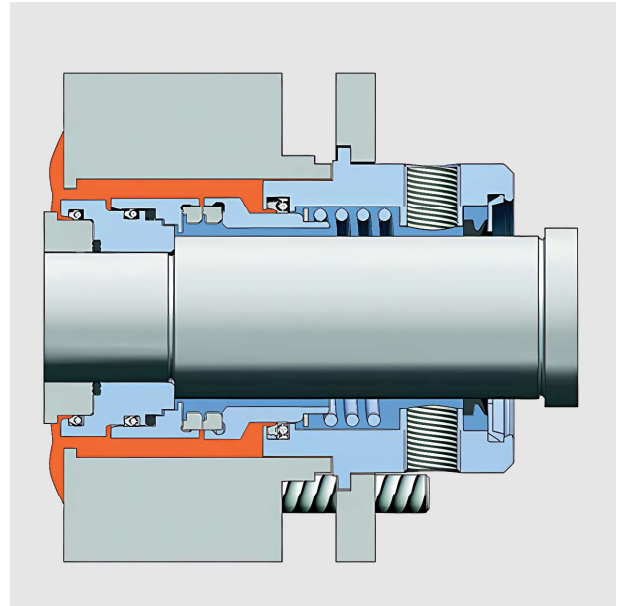

- ▶ **Equiv. John Crane Type SEW**
- ▶ **Single Seal - Safematic**
- ▶ **Suits Sulzer APP & APT Pumps**
- ▶ **Balanced Design**
- ▶ **O-ring / parallel-spring pusher**

Type SEW is a seal operating on a non-pressurised water rinsing (quench) principle, and it is designed for the most demanding applications in the pulp industry, where reliable and long-lasting operation is required from a seal.

Typical applications include stock pumps at pulp mill washing and screening facilities as well as high temperature condensate pumps. Type SEW seal is especially designed for Sulzer APP and APT pump series.

▶ **Operating conditions**

Temperature: up to 150°C
 Pressure: up to 15 barg, 220 psig
 Speed: up to 20m/s, 4000 fpm

▶ **Material Options**

Rotary Face: SiC
 Stationary Face: CAB or SiC
 Elastomer: PTFE, V or EP
 Metal Parts: Stainless Steel

EQUIVALENT

Crane: SEW

SIZES

30mm
 40mm
 50mm
 60mm
 80mm
 90mm