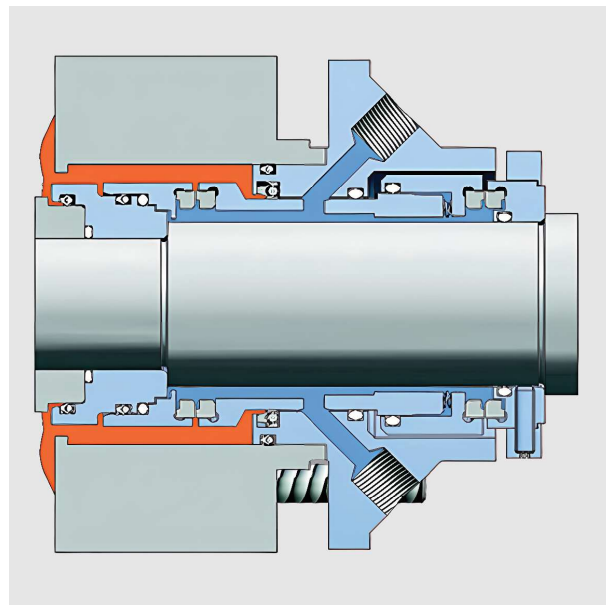

HSE2

'JOHN CRANE TYPE SE2 - SAFEMATIC'
SPECIFICATION SHEET

- ▶ **Equivalent John Crane SE2**
- ▶ **Double Seal - Cartridge**
- ▶ **Suits Sulzer APP & APT Pumps**
- ▶ **Balanced Design**

The double-balanced design of Safeseal Type SE2 ensures reliable and long-lasting operation under the most demanding conditions. This seal is typically used in pumps for abrasive and environmentally hazardous liquids in cooking, evaporation and causticising facilities in pulp mills.

Type SE2 is especially designed for Sulzer APP and APT pump series.

▶ **Operating conditions**

Temperature: up to 180°C
 Pressure: up to 20 bar, 290 psig
 Speed: up to 20m/s, 4000 fpm

▶ **Material Options**

Inboard Faces: SiC/CAB
 Outboard Faces: SiC/SiC
 Elastomer: PTFE, V or EP
 Metal Parts: Stainless Steel

EQUIVALENT

Crane: SE2

VARIANTS

SE2C

Dual, balanced cartridge seal for Sulzer Scanpump

SE2CF

Dual, balanced cartridge seal with flush for Sulzer Scanpump

SE2-APR

With circulation device

SIZES

30mm
 40mm
 50mm
 60mm
 80mm
 90mm
 100mm