

HJCS2P

'JOHN CRANE TYPE JCS2P - SAFEMATIC' SPECIFICATION SHEET

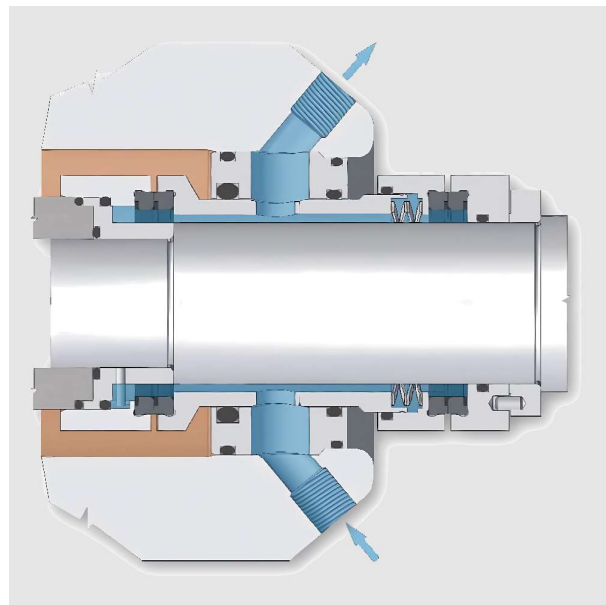

- ▶ **Equivalent John Crane JCS2P**
- ▶ **Double Seal - Safematic**
- ▶ **Suits Sulzer AHLSTAR[®] Pumps**
- ▶ **Balanced Design**
- ▶ **O-ring / wave-spring pusher**

The double-balanced design of Safeseal Type JCS2P ensures reliable and long-lasting operation under the most demanding conditions. This seal is typically used in pumps for abrasive and environmentally hazardous liquids in pulp and paper mills.

Applications include also demanding services in food, metal and fertilizer processes. Type JCS2P seal is especially designed for Sulzer AHLSTARUP pump Series.

▶ **Operating conditions**

Temperature: up to 180°C
 Pressure: up to 25 bar, 360 psig
 Speed: up to 20m/s, 4000 fpm

▶ **Material Options**

Inboard Faces: SiC/SiC
 Outboard Faces: SiC/SiC
 Elastomer: PTFE, V or EP
 Metal Parts: Stainless Steel

EQUIVALENT

Crane: JCS2P

VARIANTS

JCS2A

Double application-specific seal for Sulzer liquid ring pumps and Andritz ACP pumps

JCS2M

Double application-specific seal for Sulzer multi-stage pumps

JCS12-MC

Double application-specific seal for Andritz MC-pumps

JCS2E

Double application-specific seal for Sulzer hot liquid pumps

SIZES

30mm
 40mm
 50mm
 60mm
 80mm