

HGSDCR

'H/GRU/190595 & H/GRU/190596' SPECIFICATION SHEET

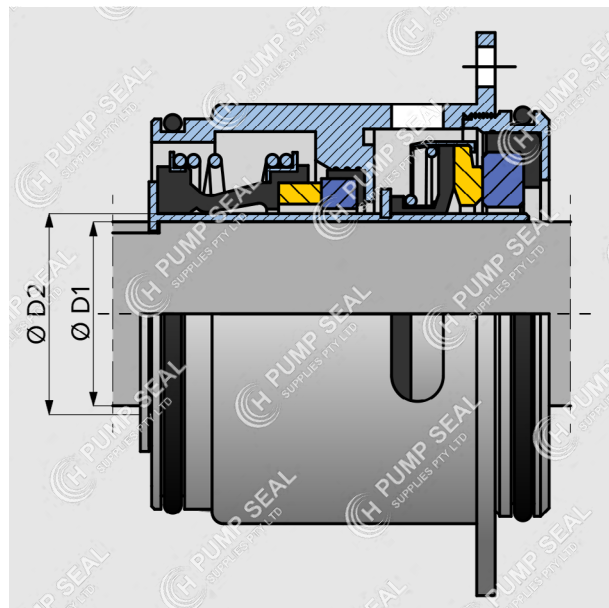

- ▶ **Double Cartridge Seal**
- ▶ **Suits SE1/V, SL1/V Pumps**

The shaft seal consists of two mechanical seals and separates the motor from the pumped liquid.

The shaft seal is a cartridge seal that enables easy service. The combination of the primary and secondary seals in a cartridge results in a shorter assembly length compared to conventional shaft seals.

Furthermore, this design minimises the risk of incorrect fitting.

The primary seal is SiC/SiC and the secondary is CAB/CER

INCLUDED PARTS

Cartridge Housing
Primary Seal
Secondary Seal

PUMP COMPATIBILITY

Replaces the (pos. 105) shaft seal cartridge in:

SE1 / SEV

SL1 / SLV