

HGCR

'H/GRU/190528 & H/GRU/190529' SPECIFICATION SHEET

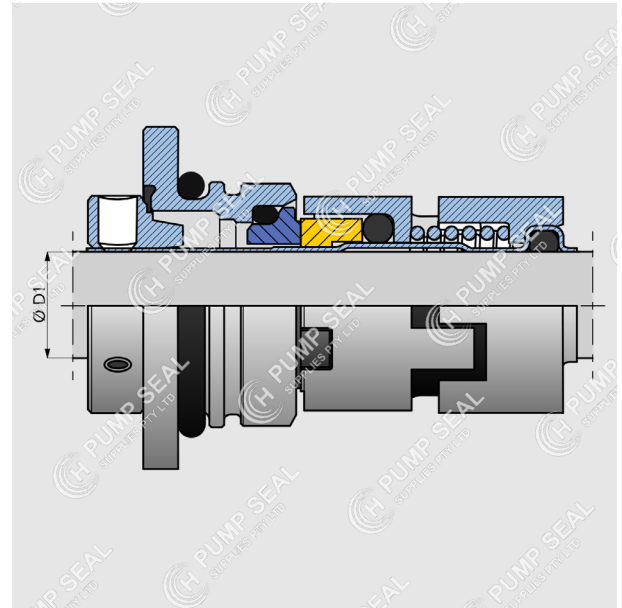
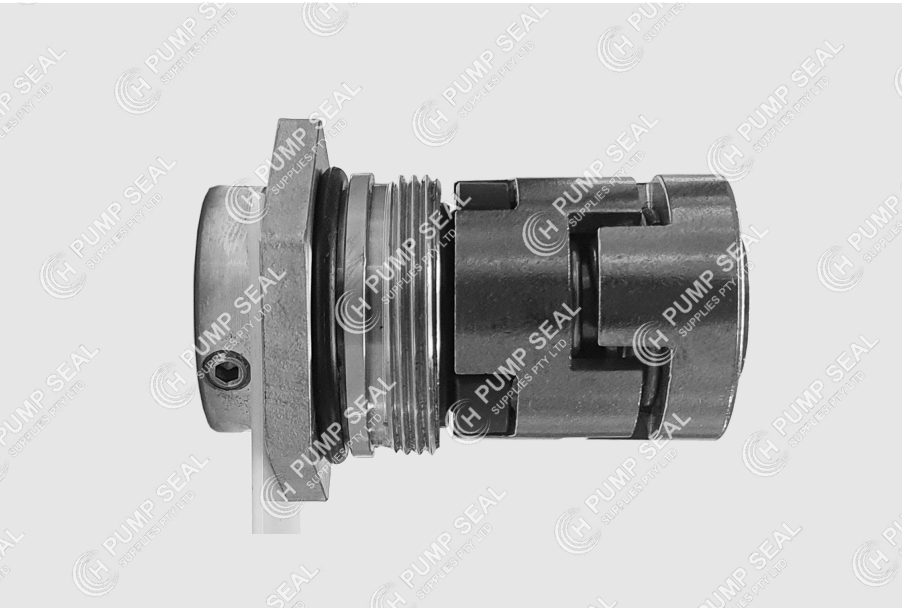

- ▶ Cartridge seal unit
- ▶ Screw-fit
- ▶ Balanced
- ▶ Suits CR pumps
- ▶ O-ring mounted
- ▶ Grub-screw driven

This seal is assembled in a cartridge unit which makes replacement safe and easy. It is supplied with a setting clip which should be pulled out once grub-screws are set.

The balanced design makes this o-ring seal type suitable for high-pressure applications

- ▶ Material codes
- HQQE
HQQV

EQUIVALENT

Type H
Type 953

PUMP COMPATIBILITY

Replaces the cartridge seal in

CR Vertical Multistage Pumps:

CR 1, 3, 5

= 12mm

CR 10, 15, 20

= 16mm