

HFD

'GODWIN DRI-PRIME SEALS' SPECIFICATION SHEET

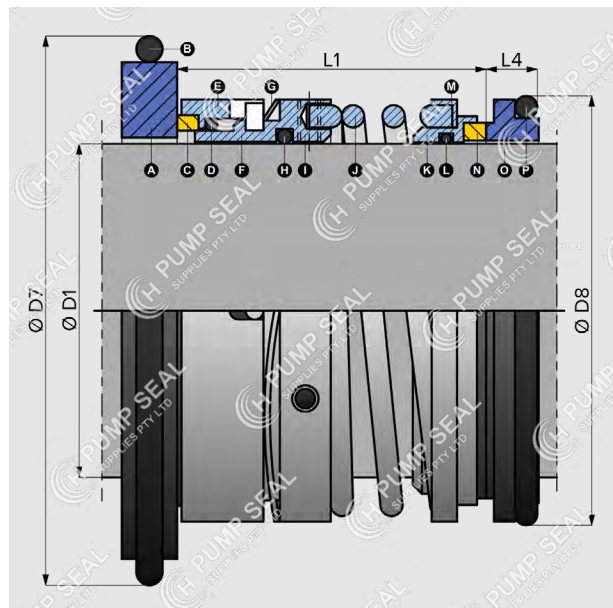

- ▶ Suits Godwin Dri-Prime pumps
- ▶ Special HF inboard seal
- ▶ Spring-driven outboard seal

HFD is designed to replace the "Type 2" alternatively configured double mechanical seals for Godwin Dri-Prime pumps.

The seal uses the same HF - single seal rotary but the outboard seal is spring leg & slot-driven.

INCLUDED PARTS

- A** Block Seat
- B** O-ring
- C** Rotary Face
- D** O-ring
- E** Rotary Holder
- F** Rotary Collar
- G** Wave Spring
- H** O-ring
- I** Set Screws
- J** Outboard Spring
- K** Outboard Rot. Holder
- L** O-ring
- M** Spring Collar
- N** Outboard Rotary Face
- O** Outboard Stationary
- P** O-ring

EQUIVALENT

- 38-1370-9912 (Rotary)
- 38-1432-9912 (Rot. Face)
- 38-1336-9913 (Seat)
- 38-1283-1112 (O-ring)

- Type 1653D
- 38-1534-9912 (Rotary)
- 38-1565-9912 (Inb. Face)
- 38-1533-9912 (Outb. Face)
- 38-1532-9913 (Outb. Seat)
- 38-1564-9912 (Inb. Seat)
- 3809324112A (O-ring)
- 3806664112A (O-ring)

GPHL225250MSK46 (Kit)

PUMP COMPATIBILITY

HFD Double mechanical seals available in:
Shaft Sizes: **60mm & 75mm**