

HCR4

'4-BOLTED CARTRIDGE SEAL' SPECIFICATION SHEET

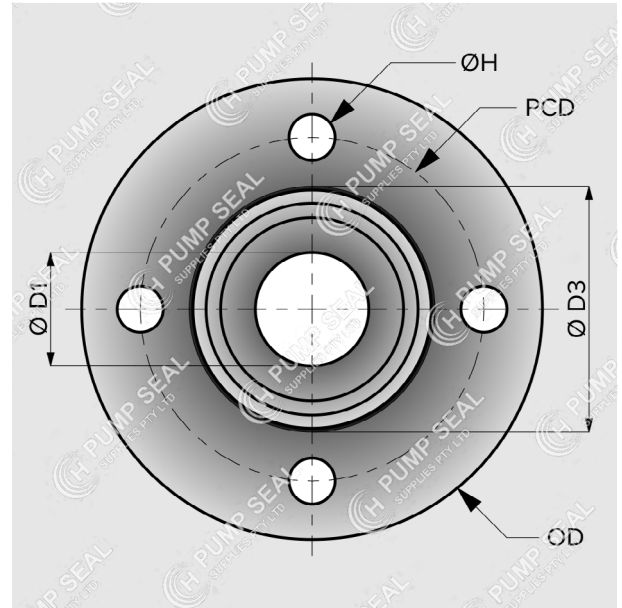

- ▶ **Cartridge seal unit**
- ▶ **Bolt-fitted**
- ▶ **Balanced**
- ▶ **O-ring mounted**
- ▶ **Grub-screw driven**

Cartridge seal replacement to suit Vertical Multistage pumps with bolt-in installation via a seal plate with 4 holes.

The balanced design makes this o-ring seal type suitable for high-pressure applications

- ▶ **Operating conditions**

Temperature: -20°C to +150°C
Pressure: up to 17 bar, 250 psi

- ▶ **Materials**

SIC/SIC/EP

EQUIVALENT

Type S
SQQE

PUMP COMPATIBILITY

Replaces the Type "S" cartridge seal in
SBI or PVMI Vertical Multistage Pumps:

SBI, PVMI 1, 3, 5

= 12mm

SBI, PVMI 10, 15, 20

= 16mm

SBI, PVMI 32, 45, 64, 90

= 22mm

SBI, PVMI 120, 150

Replaces the cartridge seal in

Javelin JV Vertical Multistage Pumps:

JV 1, 3, 5

= 12mm

JV 10, 15, 20

= 16mm

JV 32, 45, 64, 90

= 22mm