

HCR3

'3-BOLTED CARTRIDGE SEAL' SPECIFICATION SHEET

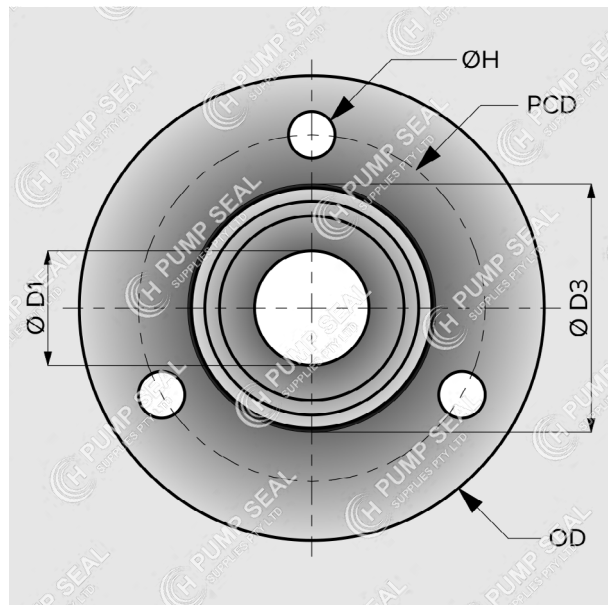

- ▶ Cartridge seal unit
- ▶ Bolt-fitted
- ▶ Balanced
- ▶ O-ring mounted
- ▶ Grub-screw driven

Cartridge seal replacement to suit Vertical Multistage pumps with bolt-in installation via a seal plate with 3 holes.

The balanced design makes this o-ring seal type suitable for high-pressure applications

▶ **Operating conditions**

Temperature: -20°C to +150°C

Pressure: up to 17 bar, 250 psi

▶ **Materials**

SIC/SIC/EP

EQUIVALENT

aftermarket

PUMP COMPATIBILITY

Replaces the cartridge seal in Davey VM pumps:

VM 1, 3, 5	= 12mm
VM 10, 16, 20	= 16mm
VM 32, 42, 65, 90 (4-bolts)	= 22mm

Replaces the cartridge seal in CNP CDM(F) pumps:

CDM(F) 1, 3, 5	= 12mm
CDM(F) 10, 16, 20	= 16mm
CDM(F) 32, 42, 65, 90 (4-bolts)	= 22mm