

# H8TUD

## 'TYPE 8-1T DOUBLE' SPECIFICATION SHEET

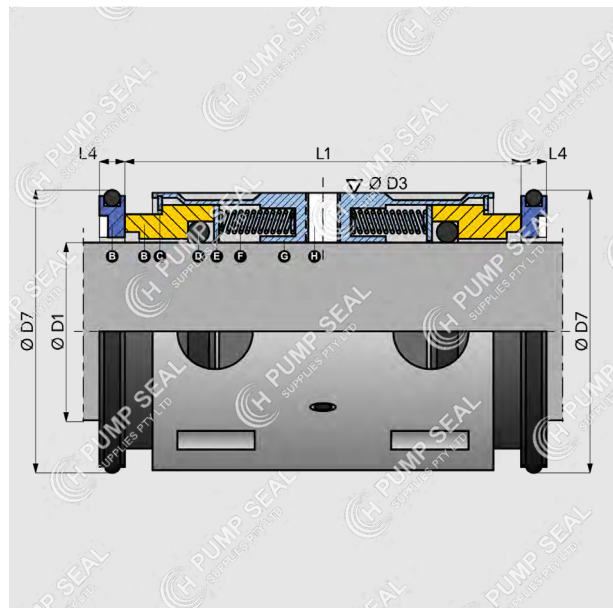

- ▶ Suits Fibroc pumps
- ▶ Double Seal
- ▶ Multi-spring arrangement
- ▶ Unbalanced
- ▶ Corrosive fluids handling

H8TUD is designed to replace the double mechanical seals found in Fibroc 1500 & 1600 series horizontal fiberglass ANSI pumps.

It is a multi-spring double seal in a single back-to-back unit.

▶ **Material Options**

Inboard Faces: SiC/SiC  
 Outboard Faces: CAB or SiC/SiC  
 Elastomer: N, V or EP  
 Metal Parts: Stainless Steel

**INCLUDED PARTS**

- A Stationary
- B Rotary Face
- C Snap Ring
- D O-ring
- E Thrust Ring
- F Multi-spring
- G Rotary Holder
- H Set Screws

**EQUIVALENT**

- 8-1T Double
- 28944C0102
- 08931C0402
- 08973C0102

**DIMENSIONS**

D1	D3	D7	L4	L1
1.375"				
2.125"	71.4	2.875"	73.03	8.0
2.875"				