

H87D

'TYPE 87 DOUBLE'

SPECIFICATION SHEET

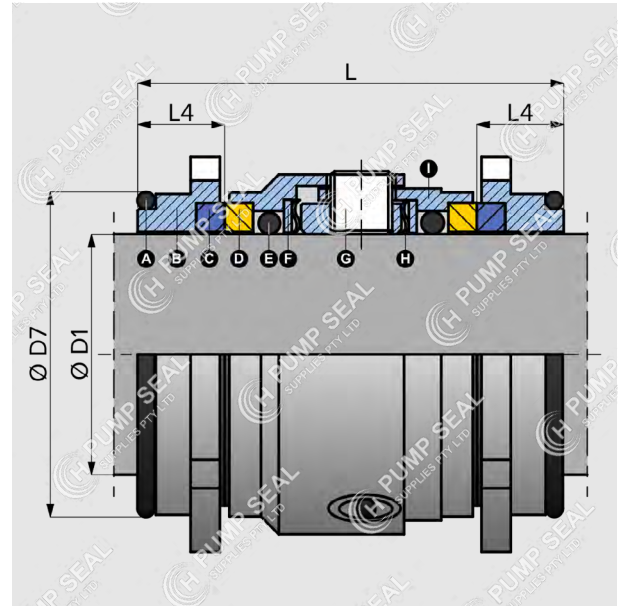

- ▶ **Double Seal**
- ▶ **High pressure barrier fluid**

H87D is the double seal arrangement of the H87 seal for use in Alfa Laval SRU series pumps. It is used to contain a high pressure barrier fluid

- ▶ **Operating conditions**

Temperature: -30°C to +260°C
 Pressure: up to 17 bar, 245 psi
 Speed: up to 20m/s, 4000 fpm

- ▶ **Material options**

Inboard Seal: TC/TC inserted
 SiC/SiC inserted
 Outboard Seal: TC/TC inserted
 SiC/SiC inserted
 Elastomer: N, V or EP
 Metal Parts: S.S.

PARTS

- A O-ring
- B Stationary Holder
- C Stationary Face
- D Rotary Face
- E O-ring
- F Thrust Ring
- G Set Screw
- H Wave Spring
- I Housing

EQUIVALENT

Type 87 Double
 "EI" or "EC" Seats
 1694

DIMENSIONS

D1	D7	L4	L
20mm	30.00	-	49.5
30mm	41.30	11.1	53.0
35mm	46.95	11.3	55.5
45mm	58.25	11.8	58.5
55mm	69.55	13.2	69.5
75mm	92.15	-	75.0

PUMP COMPATIBILITY

Replaces the mechanical seals in:

Alfa Laval SR Range:
 SR1, SR2, SR3, SR4, SR5, SR6

Alfa Laval SRU Range:
 SRU1 / 005, SRU1 / 008
 SRU2 / 013, SRU2 / 018
 SRU3 / 027, SRU3 / 038
 SRU4 / 055, SRU4 / 079
 SRU5 / 116, SRU5 / 168
 SRU6 / 260, SRU6 / 353

NMOG
 LKPL
 TSR
 GHPD