

H6KB

'HIDROSTAL - TYPE M - SEALS' SPECIFICATION SHEET

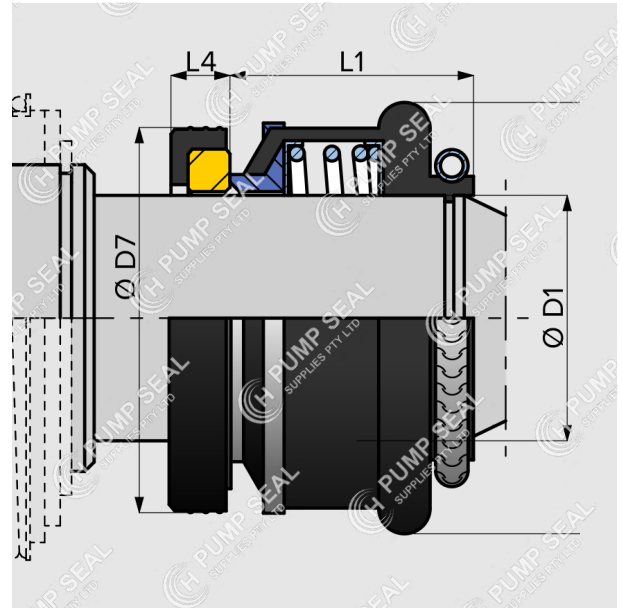

- ▶ Suits Hidrostal pumps
- ▶ Replaces Type "M" seals
- ▶ Internal-spring, rubber encased

H6KB replaces the Type "M" seal codes in Hidrostal pumps. Typically used in the product-side position in the tandem seal arrangement.

The TC/SiC face combination ensures no molecular welding can occur. Springs are completely encased in a rubber boot to avoid fouling by stringy materials

EQUIVALENT

Type 68

DIMENSIONS

D1	OEM	D7	L4	L1	L
0.625"		SXH	30.14	10.0	22.5 32.5
1.125"	M1.1	1.750"	44.45	11.0	28.1 39.1
1.500"	M1.5	2.125"	53.98	11.0	35.0 46.0
2.000"	M2.0	2.750"	69.85	12.7	45.3 58.0