

H65

'H/INO/65'

SPECIFICATION SHEET

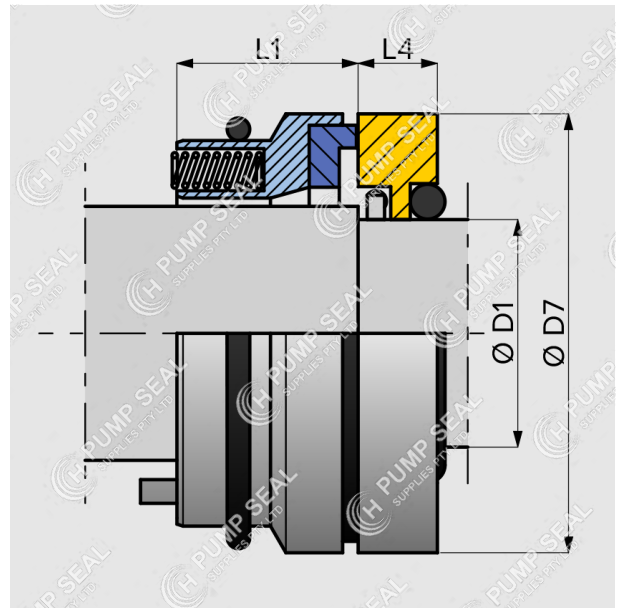

- ▶ **Multi-spring pusher**
- ▶ **Suits Inoxpa Prolac S pumps**
- ▶ **Imperial Shaft Sizes**

H65 - is an Inoxpa-specific multi-spring seal designed for the PROLAC S sanitary centrifugal pump range. It comes standard as the non-cooled single mechanical seal option, and is also used as the lower seal in the cooled double seal option.

Shaft sizes are Imperial

The o-ring at the back of the seat is designed to be pushed against the impeller

▶ **Material Options**

Rotary Face:	CAB, SIC
Stationary Face:	S.S, SIC
Elastomer:	N, V, EP
Metal Parts:	Stainless Steel

EQUIVALENT

Type 50

PUMP COMPATIBILITY

Suits Inoxpa PROLAC S Sanitary Centrifugal Pump range