

# H3000

## 'HIDROSTAL - TYPE X - SEALS' SPECIFICATION SHEET

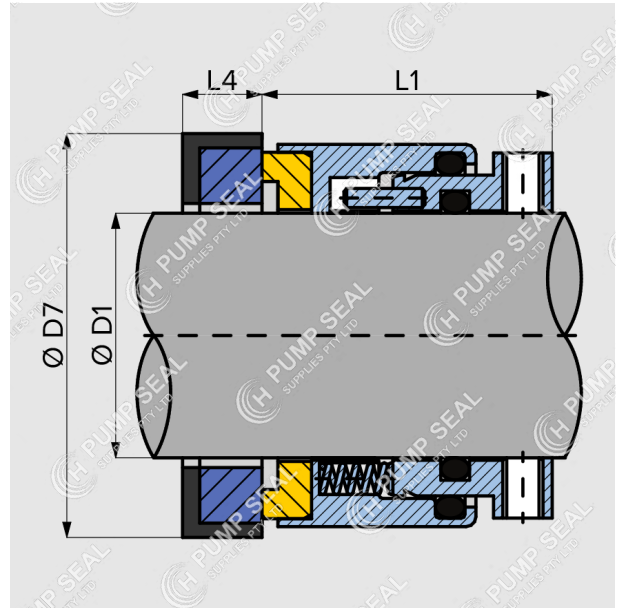

- ▶ Suits Hidrostal pumps
- ▶ Replaces Type "X" seals
- ▶ S.S. shroud seal, balanced

H3000 replaces the Type "X" seal codes in Hidrostal pumps. Typically used to replace either seals in the tandem seal arrangement.

Designed with internally protected springs to prevent clogging.

### EQUIVALENT

Type 41

### DIMENSIONS

D1	OEM	D7	L4	L1	L
1.125"	X1.1	1.750"	44.45	8.1	38.1
1.500"	X1.5	2.125"	53.98	8.1	31.6
2.000"	X2.0T	2.750"	69.85	12.7	38.1
2.500"	X2.5	3.375"	85.73	14.2	46.1
3.000"	X3.0	3.875"	98.43	15.6	52.5
95mm	X095	4.875"	123.83	17.4	62.0
100mm	X100	4.875"	123.83	17.4	62.0
115mm	X115	5.625"	142.88	12.5	48.3
120mm	X120	5.625"	142.88	12.5	48.3
120mm	X120H	5.625"	142.88	12.5	66.3

Sizes 95mm+ utilise o-ring mounted stationaries