

# H293

## 'TRI-CLOVER SANITARY SEALS' SPECIFICATION SHEET

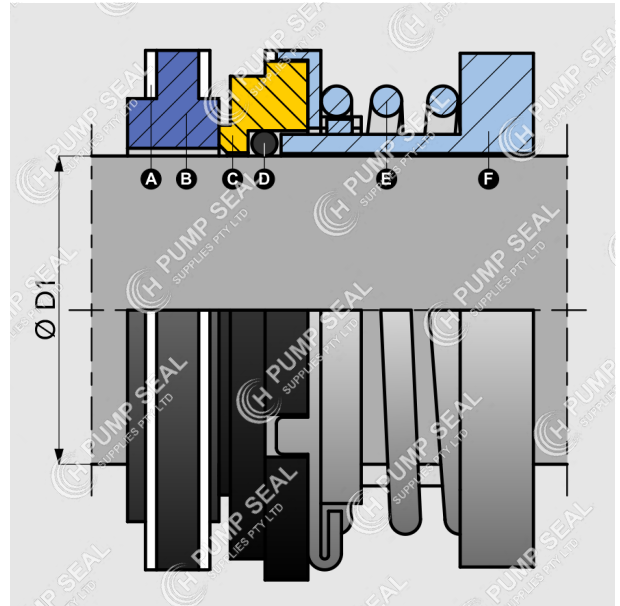

### ► Type D - External Balanced

Externally mounted, rotary only, designed to be run directly against the S.S. pump housing or backing plate.

Suitable for multi-purpose use

### ► Type DG - Clamped-In Seat

Complete seal with hard-faced seat (SiC, CER or TC)

Suitable for maximum corrosion resistance in pure water applications.

### ► Type E - Double Seal

Uses parts from the Type D to contain a pressurised coolant or sealant.

Suitable for slurries, tacky products and heavy-duty applications

### ► Type F - Flushed Seal

Uses parts from the Type D to contain a low-pressure water cascading attachment.

Suitable for tacky, hot products and vacuum applications

### PARTS

- A** PTFE Gasket
- B** Clamp Seat (Type DG)
- C** Rotary Face
- D** O-ring
- E** Spring
- F** Drive Collar

### EQUIVALENT

Type 293

### PUMP COMPATIBILITY & SHAFT SIZE

Replaces the seals found in Tri-Clover made "Tri-Flo" pumps:

C Series - Close Coupled:  
C114, C216, C218, C328, C4410

SP Series - Base-Mounted:  
SP114, SP216, SP218, SP328, SP4410

CL Series - Custom-built "Complete Line" Range  
CS Series - Variants with S.S. motor shroud  
EH Series - Pedestal mounted