

H103

'TYPE 103' SPECIFICATION SHEET

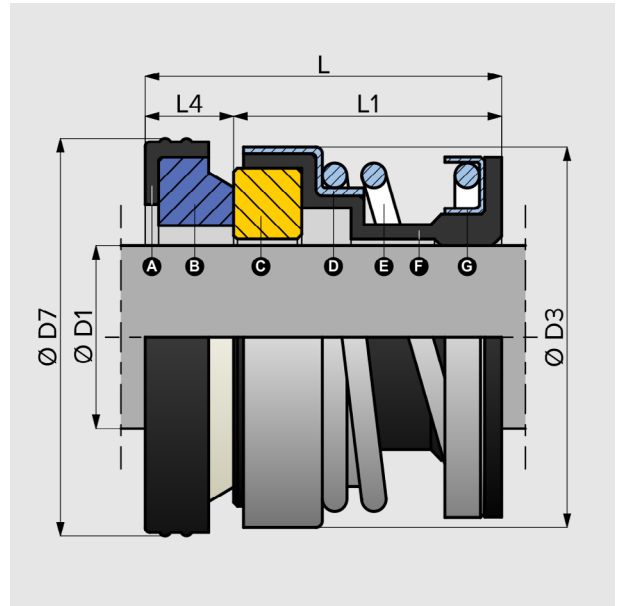
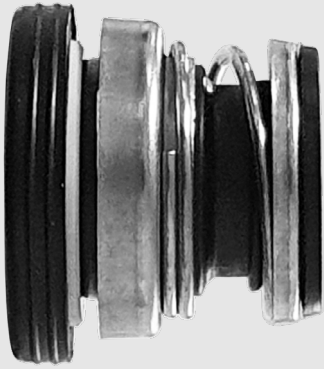

- ▶ **Compact Rubber Bellows**
- ▶ **Single Spring**
- ▶ **Suits Chinese pumps**

H103 is a compact elastomer bellows mechanical seals. It is designed to replace the mechanical seals found commonly in Chinese-made pumps.

▶ **Operating conditions**

Temperature: -30°C to +200°C
 Pressure: up to 8 bar / 116 psi
 Speed: up to 5m/s, 984 fpm

▶ **Material Options**

Rotary Face: CAB
 Stationary Face: CER
 Elastomer: N
 Metal Parts: Stainless Steel

PARTS

- A** Seat Cup
- B** Stationary Face
- C** Rotary Face
- D** Retainer
- E** Spring
- F** Rubber Bellows
- G** Ferrule

EQUIVALENT

103

DIMENSIONS

D1	D3	D7	L4	L1	L
10mm	22.5	26.0	5.0	15.5	20.5
12mm	22.5	26.0	5.0	15.5	20.5
12mm	22.5	26.0	7.0	15.5	22.5
14mm	27.0	30.0	5.8	15.5	21.3
16mm	30.0	35.0	5.0	15.5	20.5
17mm	30.0	35.0	5.0	15.5	20.5
18mm	30.0	35.0	5.0	15.5	20.5